

Laboratory 7

Digital Circuits - Logic and Latching

Required Components:

- 1 330 Ω resistor
- 4 1k Ω resistor
- 2 0.1 μ F capacitor
- 1 2N3904 small signal transistor
- 1 LED
- 1 7408 AND gate IC
- 1 7474 positive edge triggered flip-flop IC
- 1 7475 data latch IC
- 3 NO buttons

7.1 Objectives

In this laboratory exercise you will use TTL (transistor-to-transistor logic) integrated circuits (ICs) to perform combinational and sequential logic functions. Specifically, you will learn how to use logic gates and flip-flops. You will use these components to build a simple circuit to control the display of an LED based on the past and current state of various switches or buttons.

7.2 Introduction

The ICs you will be handling in this laboratory exercise require digital inputs and produce digital outputs. A binary digital signal is a sequence of discrete states, in contrast to an analog signal that varies continuously. Figure 7.1 shows the difference between digital and analog signals. The sampled digital data is a discrete representation of the analog signal. The data is represented by a series of bits.

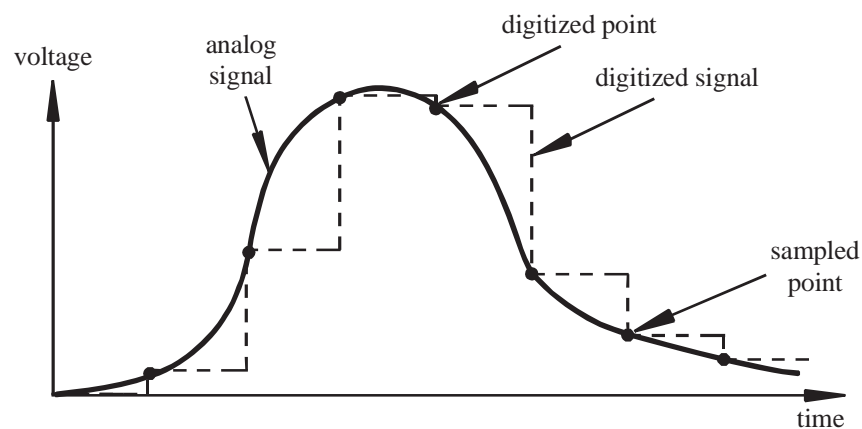

Figure 7.1 Analog and Digital Signals

A binary (digital) signal may exist in only one of two states defined as a voltage high and low. Many types of devices are available for processing the information contained within a digital signal (i.e., a sequence of 0s and 1s). The ICs you will see in this laboratory exercise are TTL (Transistor-Transistor Logic) circuits. TTL devices process digital signals that have a high level defined from 3.5 to 5 V and a low level between 0 to 0.7 V. Note that 0.7 V to 3.5 V is a dead zone. Usually, but not always, a voltage high is equivalent to a logic high. Each of the signals at the input and output terminals of a digital device can exist in only one of two possible states, a voltage low corresponding to a binary zero, or a voltage high corresponding to a binary one.

There are hundreds of TTL ICs (also called chips) available, each with its own functionality. There are many companies that manufacture ICs, but they all use a standard numbering method to identify the ICs. Each chip manufacturer publishes a set of data books that describe how each of the ICs work. In the Lab, we have TTL data books from National Semiconductor, Texas Instruments, and Motorola. These books all contain the same basic information: chip pin-outs, truth tables, operating ranges, and chip-specific details. At the front of each book is a functional index that lists all the chips described in the book according to their function. This is the first place you should look when trying to find a chip for a particular application. For example, let's say you need an AND gate (as you do for this exercise). The Motorola Data book lists a "Quad 2-Input AND Gate" with a device number of MC54/74F08. The National Semiconductor data book also lists a "Quad 2-Input AND Gate," but with a device number of DM74LS08. For most purposes, the only numbers that are important are the "74," which corresponds to the standard TTL series, and the "08," which identifies the chip function (in this case, a Quad 2-Input AND). A standard "Quad 2-Input AND Gate" can be referred to simply as a "7408" for any manufacturer. The information in the data book is organized in numerical order according to the chip's unique number (in this case, 08). Knowing the chip number from the functional index, you can now find the chip information in the data book.

7.3 Data Flip-flops and Latches

There are many digital circuit applications where you may need to store data for later use. One way to do this is through the use of flip-flops. The bistable data latch (see Figure 7.2) is a flip-flop that is useful in many applications. The data latch has a data input (D), a clock input (CK), and output Q. Most flip-flops include complementary outputs where \bar{Q} is the inverse of Q. With a data latch, the data input gets passed to or blocked from the output depending upon the clock signal. When CK is high, $Q=D$ (i.e., the output tracks the input). When CK is low, the D input is ignored and the last value of Q (the value of D when CK last went low) is stored (latched). This memory state of the flip-flop (when CK is low) is indicated in the truth table with Q_0 (the last value latched). The entire functionality is summarized in the truth table shown in Figure 7.2. An X in a truth table indicates that a signal value may have either value (H or L). For example, for the data latch, when CK is low, the input D has no effect on the output Q.

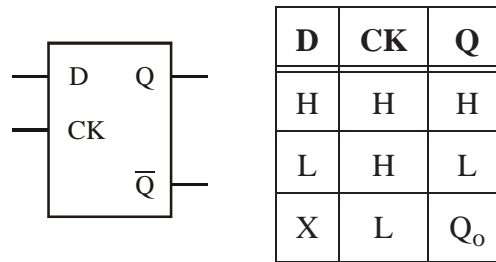

Figure 7.2 Data Latch (7475)

The data latch is sometimes referred to as a level-triggered device since it is active (or triggered) based on the level (high or low) of the clock input, in this case high. A more common type of triggering for flip-flops is edge triggering where the output can change state only during a transition of the clock signal. Devices that respond when the clock transitions from low-to-high (indicated by an up arrow in a truth table) are referred to as positive edge triggered devices. Devices that respond when the clock transitions from high-to-low (indicated by a down arrow in a truth table) are referred to as negative edge triggered devices. Figures 7.3 and 7.4 summarize the functionality of positive and negative edge-triggered D-type flip-flops. Positive edge triggering is indicated by a triangle at the clock input. Negative edge triggering is indicated by an inversion circle and triangle at the clock input.

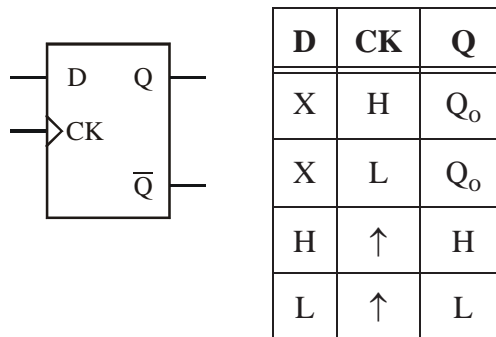

Figure 7.3 Positive Edge-triggered D flip-flop (7474)

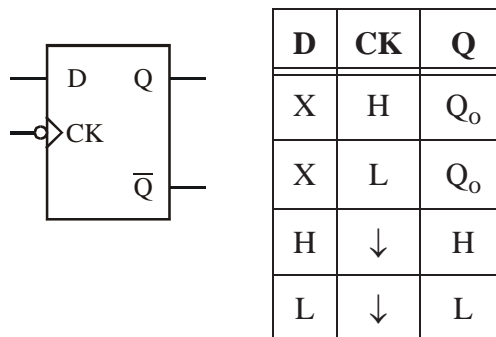

Figure 7.4 Negative Edge-triggered D flip-flop

Figures 7.5 through 7.7 show pin-out and schematic diagrams from the datasheets for various TTL devices used in this exercise. Note that the 7408 includes four AND gates numbered 1 through 4 (e.g., $1Y = 1A \cdot 1B$). The 7474 includes two positive edge-triggered data flip-flops, and the 7475 includes four positive level-triggered data flip-flops (AKA "data latches"). **Note that the 7474 has preset and clear features. Because these features are active low, these pin should be connected to 5V to deactivate them.**

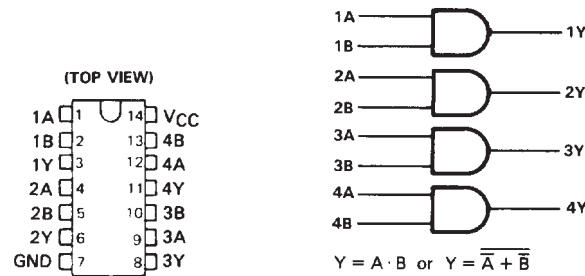

Figure 7.5 Pin-out and schematic symbol diagrams for the 7408

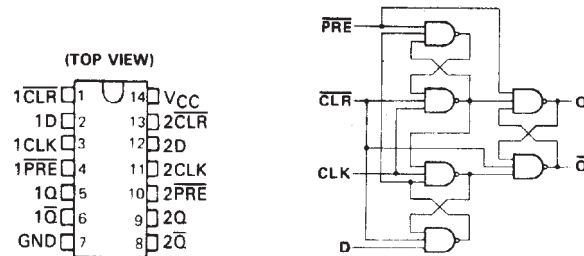

Figure 7.6 Pin-out and schematic symbol diagrams for the 7474

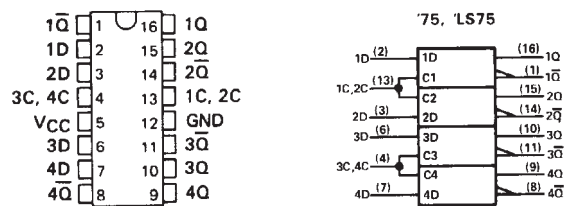

Figure 7.7 Pin-out and schematic symbol diagrams for the 7475

7.4 Hints on assembling and troubleshooting breadboard circuits including integrated circuits

Please follow the protocol listed below when using breadboards to construct and test prototype circuits containing integrated circuits (ICs). Generally, if you carefully follow this protocol you will avoid a lot of frustration

- (1) Start with a clearly drawn schematic illustrating all components, inputs, outputs, and connections.
- (2) Draw a detailed wiring diagram, using the information from handbooks regarding device pin-outs. Label and number each pin used on each IC and fully specify each component. This will be your wiring guide.
- (3) Double check the functions you want to perform with each device.
- (4) Insert the ICs into your breadboard, and select appropriately colored wire (i.e. red for +5V, black for ground, other colors for signals).
- (5) Wire up all connections, overwriting the wiring diagram with a red pen or highlighter as you insert each wire. Use appropriate lengths (~ 1/4") for exposed wire ends. If the ends are too short, you might not establish good connections; and if too long, you might damage the breadboard. Also be careful to not insert component (e.g., resistor and capacitor) leads too far into the breadboard holes. This can also result in breadboard damage.
- (6) Double check the +5V and ground connections to each IC.
- (7) Set the power supply to +5V and turn it off.
- (8) Connect the power supply to your breadboard and then turn it on.
- (9) Measure signals at inputs and outputs to verify proper functionality.
- (10) If your circuit is not functioning properly, go back through the above steps in reverse order checking everything carefully. If you are still having difficulty, use the beep continuity-check feature on the multimeter to verify all connections.
- (11) When removing ICs from the breadboard, use a chip-puller tool to limit the potential for pin damage.
- (12) See more useful information and guidance in Lab 15.

And for additional troubleshooting advice, especially for more-complicated circuits and the Project, see Section 2.3 in Lab 2 and Section 15.5 in Lab 15.

7.5 Laboratory Procedure / Summary Sheet

Group: _____ Names: _____

- (1) Using the datasheet pin-out diagrams (Figures 7.5 through 7.7), draw a complete and detailed wiring diagram (showing all connections and all pin numbers) for the circuit schematic shown in Figure 7.8, using a 7474 positive edge-triggered flip-flop. Carefully **label and number all pins that are used on each IC, including power and ground**. You might find Figure 7.9 helpful as a reference because it shows a photograph of a partially-completed circuit.

Be sure to **connect 5V and ground to both ICs** (otherwise, they won't function). **Also note that the 7474 has preset and clear features. Because these features are active low, these pins should be connected to 5V to deactivate them.**

Note - It is good practice to include a 0.1 μF capacitor across the power and ground pins of each IC (not shown in Figure 7.8 or Figure 7.9). This helps filter out transients that could occur on the power and ground lines during switching. The capacitors are especially important in more complicated circuits where a single power supply may be providing reference voltages and switched current to numerous components.

You will need to submit your detailed wiring diagram with your Lab summary and answered questions at the end of the Lab (see Question 4).

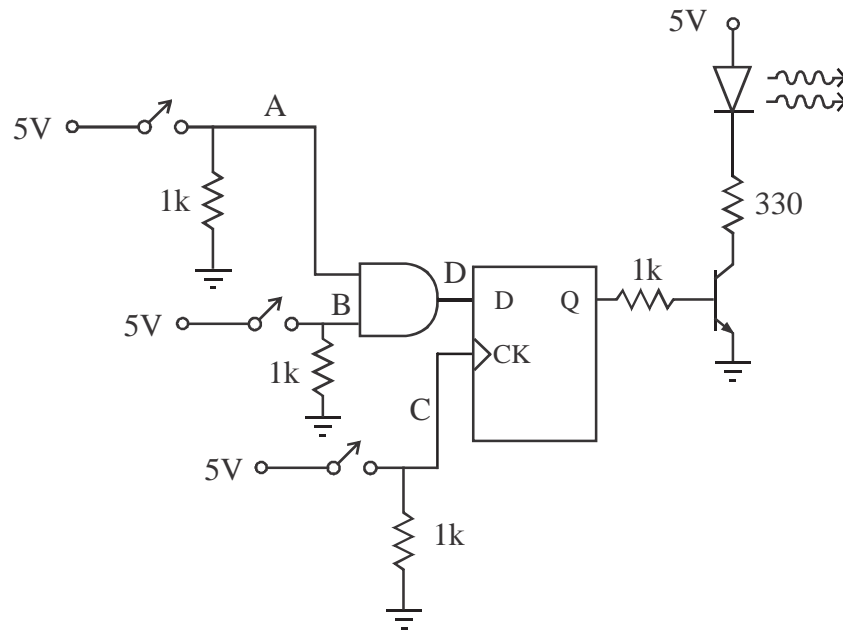

Figure 7.8 Circuit Schematic with Switches, Logic Gate, and Flip-flop

- (2) Using the detailed wiring diagram you created in Step 1, construct the circuit. Again, Figure 7.9 can be helpful as a reference because it shows the partially completed circuit; although, your main reference should be the wiring diagram you created in Step 1.

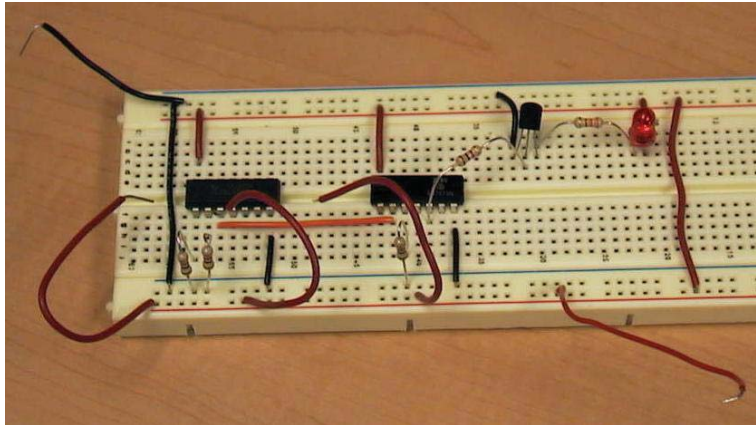

Figure 7.9 Photograph of the Partially-Completed Circuit

NOTE - Don't use this photograph to build your circuit (because it is not complete). Instead, use the detailed wiring diagram you created in Step 1 above.

- (3) Complete the following timing diagram (ignoring any switch bounce effects) and test the circuit to see if the results match the theory. **Have your TA verify that your circuit is working properly before continuing.** Also, look at and think about Question 2 at the end of the Lab before continuing.

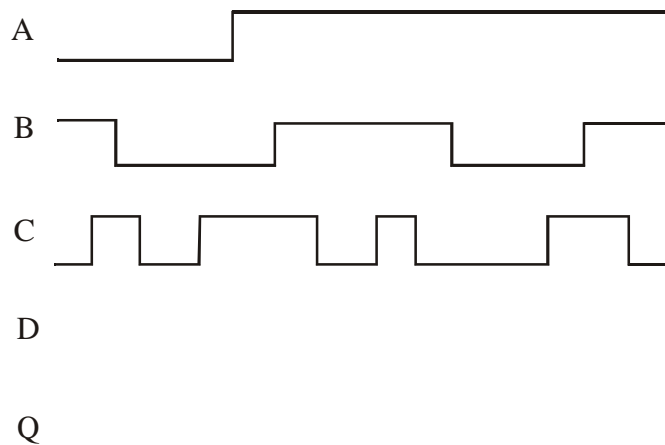

Figure 7.10 Positive-Edge-Triggered Circuit Timing Diagram

- (4) Replace the 7474 with the 7475 bistable data latch and rewire the circuit based on the circuit schematic in Figure 7.7. The circuit schematic is shown in Figure 7.11. The only difference from the previous circuit is that the D-latch is not edge triggered. Again, look at and think about Question 2 at the end of the Lab before continuing.

NOTE - When removing ICs from a breadboard, always use a "chip puller" tool to lift both ends together. Alternatively, use a small flat-head screwdriver to pry each end up a little at a time to release the IC without causing damage (e.g., bent or broken pins).

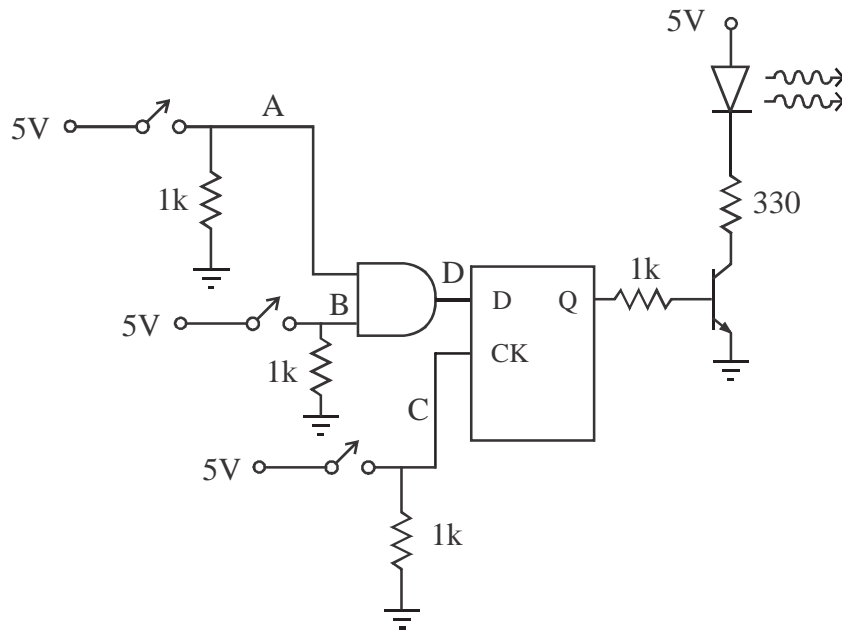

Figure 7.11 Data Latch Circuit Schematic

Complete the following timing diagram and verify the results by testing your circuit. **Have your TA verify that your circuit is working properly before continuing.**

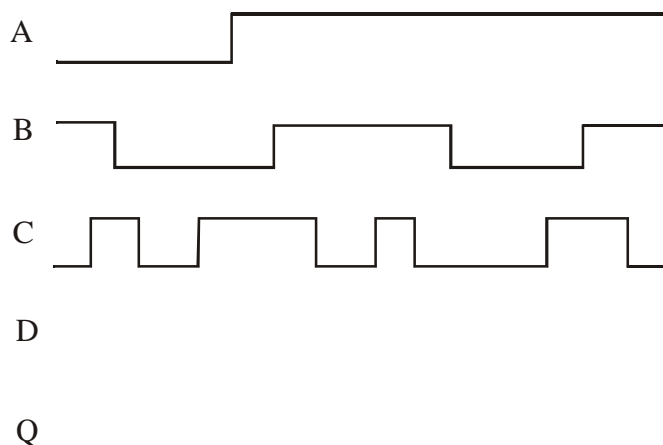

Figure 7.12 Latch Circuit Timing Diagram

LAB 7 QUESTIONS

Group: _____ Names: _____

- (1) Explain the difference between the output of the two circuits you analyzed and tested. What is the reason for the difference?

- (2) Switches and buttons often experience switch "bounce," especially when contact is made (as opposed to broken). Did bounce affect the output Q of the circuits? If so, in what cases, and why? If not, explain why you think this was the case.

For the positive-edge-triggered circuit (Figure 7.8), assuming bounce occurs during every release of button C , draw a timing diagram showing how the output (Q) would respond for the A , B , and C traces shown in Figure 7.10.

